

# EQUIPMENT SHEET

**SMIT FROME**  
MULTIPURPOSE FAST CRAFT



## CONSTRUCTION / CLASSIFICATION

Year of construction	2002
Classification	MCA Workboat Code Cat 2

## FEATURES

Compliment	6 max (2 crew)
Accommodation	Damped suspension seating, fridge, microwave, kettle, toilet
Suited for single and multibeam survey options	

## MAIN DATA

Type	Multipurpose fast craft
Gross tonnage	5 GT
Length overall	12.35 m
Beam overall	3.5 m
Max draft	0.65 m
Main engines	2xYanmar 6LYA diesel engine (350 hp)
Propulsion	2xHamilton waterjets
Max speed	35 kn
Endurance	At 26 knots approx. 200 NM
Air draft	4.25 m (mast lowered 3.35 m)
Marine radar	Chart plotter
AIS	2xVHF
GPS	Echo sounder

## LOCATION

1 of a class of 9 vessels, of which 3 are generally based at Dover, 3 at Portland and 3 at Pembroke Dock.  
Road transportable at short notice to any location in the UK.

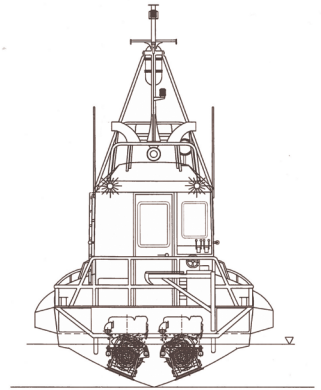
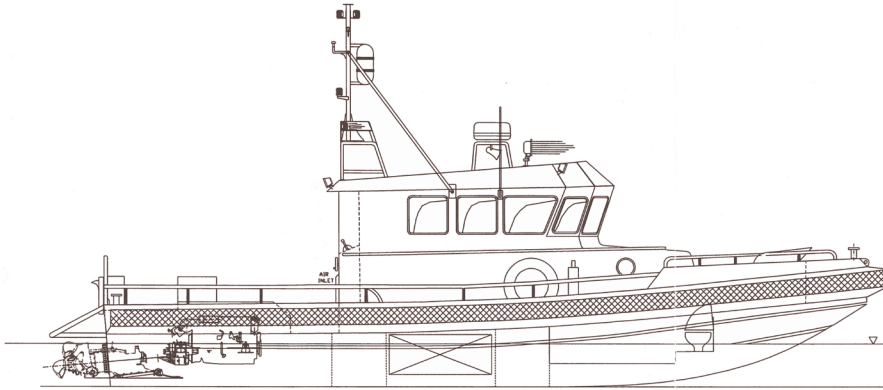

**SIDE VIEW**

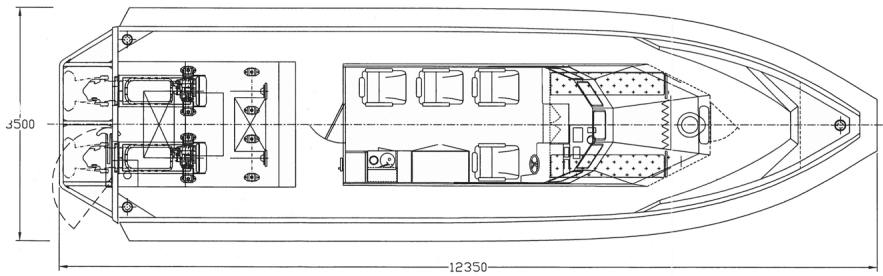

**TOP VIEW**

**Boskalis Marine Services Ltd**

Westminster House  
4 Crompton Way  
Segensworth West  
Fareham, Hampshire  
PO15 5SS, United Kingdom

T +44 1489 885933  
F +44 1489 578588

[bwl@boskalis.com](mailto:bwl@boskalis.com)  
[www.boskalis.co.uk](http://www.boskalis.co.uk)